

Häny Mixing and Injection Technology

Compact Grout Plant IC 650/725



The compact grout plants consist of the proven, standard Häny components of a mixer, agitator, and grout pump. This setup is suitable for a wide range of applications such as anchoring, sleeve pipe, contact, and backfill grouting. For higher outputs and increased quality control, the plants are also available in semi-automated and fully automated versions.

HÄNY

Mixing and Injection Technology

Compact Grout Plant

IC 650/725

Key features

- ▶ Extremely compact mixing and injection system with central lifting point for easy transport and minimum installation time
- ▶ High productivity due to ergonomically positioned operating elements
- ▶ High reliability and low-maintenance operation with good accessibility to the wear parts
- ▶ Independent of pressure ratios, the suction stroke is always carried out at high velocity in order to flush the valves and to avoid clogging

Typical applications

- ▶ Grouting of anchors, soil nails, tension cables as well as for sleeve pipe, rock, and contact injections
- ▶ Preparation and pumping of bentonite suspensions for pipe jacking and microtunneling

Pump performance

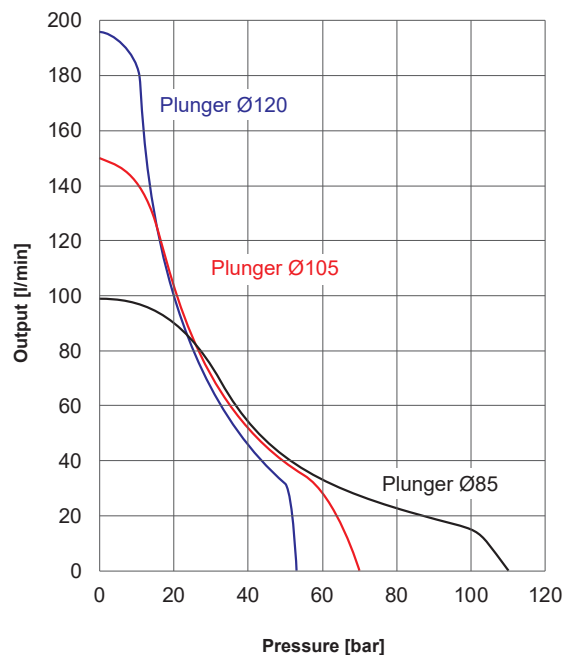

Grout pump

ZMP 725

| | |
|----------------------------|---------------------|
| Capacity IC ¹ : | 5 m ³ /h |
| Max. pressure: | 100 bar |
| Max. aggregate size: | 8 mm |
| Hydraulic tank: | 140 l |
| Pump module: | double |
| Cooling water flow rate: | 5–6 l/min |
| Cooling water connection: | BSP ½" |
| Pressure connection: | BSP 2" |

Included as standard

- Manual pressure and flow control
- Oil level and temperature sensor

Optional

- Pressure relief valve Grout pump - Agitator, manual
- Low pressure control cartridge

¹ Water to cement ratio = 1

Mixer / Agitator

| | |
|----------------------------|-------------|
| Usable content mixer: | 260 l |
| Circulation capacity: | 1,400 l/min |
| Water connection: | BSP 1" |
| Holding capacity agitator: | 350 l |

Optional

- Auxiliary mixing unit (recommended for W/C < 0.45)
- Automatic water meter 1"

Control

| |
|--------------------------------------|
| PLC with stroke counter |
| Lockable main switch, emergency stop |
| Mixer ON-OFF |
| Agitator ON-OFF |
| Pump ON-OFF |

Optional

- Remote control with 50 m cable, ON-OFF
- P/Q-Registration



Electrical data

| | |
|----------------|------------|
| Tension: | 3x 400/460 |
| Frequency: | 50 / 60 Hz |
| Nominal power: | 19 / 22 kW |

Weight and dimensions

| | |
|---------------|----------|
| Total weight: | 1,465 kg |
| Width: | 1,800 mm |
| Height: | 1,737 mm |
| Length: | 2,367 mm |

Construction and dimensions

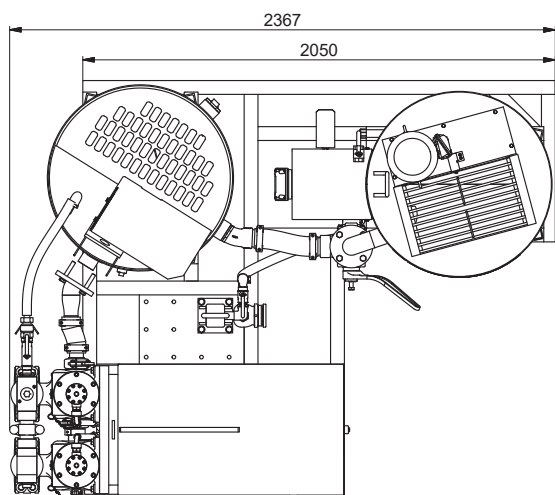
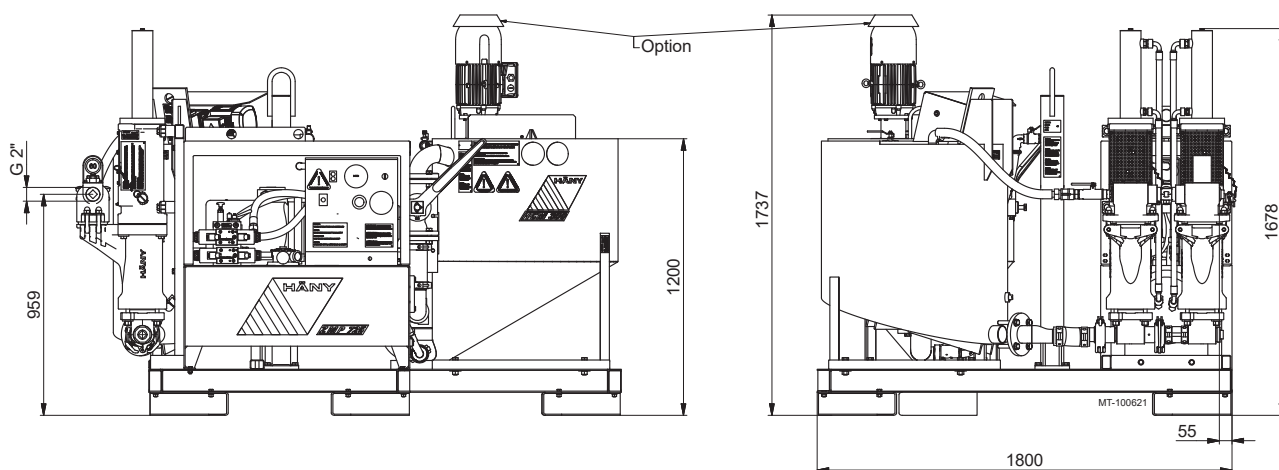

Document No.: FM2-101836 00/08; 18. Legal Notice © Copyright 2018; Häny AG, Jona/Switzerland. Any unauthorized use or copying of the contents or any part hereof is prohibited. Illustrations and photos may show equipment with optional extras. No warranty is made regarding specifications or otherwise. Specifications and equipment are subject to change without notice.



Distributed By:

Multicrete Systems Inc.

2500 Ferrier Street • Winnipeg, Manitoba R2V 4P6 CANADA

Phone: 204-262-5900 Fax: 204-262-5909 •

www.MULTICRETESYSTEMS.com

Häny AG – Mixing and Injection Technology
Buechstr. 20 | 8645 Jona/Switzerland | Phone +41 44 925 41 11 | www.haeny.com