

Häny Mixing and Injection Technology

High Shear Mixer HCM 800



The colloidal mixer is particularly suitable for the production of suspensions consisting of water, cement, ultra-fine binder, bentonite, sand, and other materials. A robust mixing tank combined with highly wear-resistant materials in the mixing pump guarantee a long service life and trouble-free operation.

High Shear Mixer

HCM 800

Key features

- ▶ Excellent mixing results thanks to the high turbulence generated by the high-speed mixing pump
- ▶ Mixing tank with conical bottom and pneumatic pinch valves for switching between mixing and transfer
- ▶ Automatic lubrication of the shaft seal
- ▶ Weighing cells for automatic batching of water and dry components
- ▶ Cleaning opening (manhole) for easy cleaning

Typical applications

- ▶ Preparation of suspensions consisting of water, cement, ultra-fine binder, bentonite, and other materials
- ▶ As a stand-alone system or in combination with agitator and injection pump

3D model



High shear mixer

Mixing pump:	TMP 40
Approx. capacity ¹ :	20 m ³ /h
Circulation capacity:	2,400 l/min
Usable content:	800 l
Max. aggregate size:	3 mm
Liquid temperature:	Max. 40°C
Water feedthrough:	DN50/100
Dry component feedthrough:	2x DN200

¹: Water to cement ratio = 1



Electrical data

Voltage:	3x 400/460 V
Frequency:	50 / 60 Hz
Nominal power:	22 / 25 kW
Nominal current:	40.1 / 41.0 A
Speed:	1,475 / 1,770 min ⁻¹

Weight and dimensions

Approx. weight:	1225 kg
Width:	1,390 mm
Height:	1,993 mm
Length:	1,710 mm

Design and dimensions

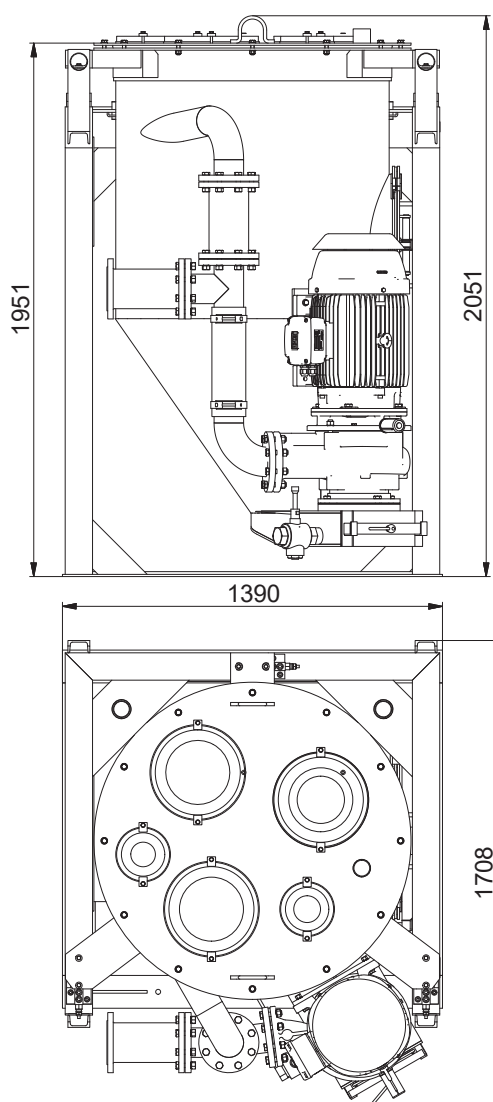

Document No. PW2-102074-00/10; 18. Legal Notice © Copyright 2018, Häny AG, Jona/Switzerland. Any unauthorized use or copying of the contents or any part hereof is prohibited. Illustrations and photos may show equipment with optional extras. No warranty is made regarding specifications or otherwise. Specifications and equipment are subject to change without notice.



Distributed By:
Multicrete Systems Inc.
2500 Ferrier Street • Winnipeg, Manitoba R2V 4P6 CANADA
Phone: 204-262-5900 Fax: 204-262-5909 •
www.MULTICRETESYSTEMS.com

Häny AG – Mixing and Injection Technology
Buechstr. 20 | 8645 Jona/Switzerland | Phone +41 44 925 41 11 | www.haeny.com