



SHOTCRETE • CONCRETE • GROUT • EQUIPMENT



SHOTCRETE



SUPPORT YOU CAN COUNT ON

As your one-stop source for shotcrete application equipment, shotcrete materials, transfer systems, grouting equipment, and associated technical support, Multicrete Systems Inc. offers leading-edge project solutions to customers worldwide.

Our energetic and multi-disciplinary team includes engineers, mining professionals, and construction specialists who supply the mining and tunneling industries with technical assistance focused on supporting shotcrete, grouting, and concrete programs. We have also offered expertise and solutions in several civil construction, new construction, and restoration ventures. On the international scale, we have supplied equipment and materials to mining companies in North, Central, and South America.

MULTICRETE SYSTEMS INC.
MULTICRETE SYSTEMS (USA) INC.



204-262-5900



204-262-5909



info@multicretesystems.com



www.multicretesystems.com



TABLE OF CONTENTS

SHOTCRETE EQUIPMENT

- Sika-Aliva ® Equipment 3, 4
- MSI Integral Shotcrete Unit 5
- MSI HW10H Hybrid-Wet Carrier 5, 9
- MSI Huron 4 Mobile Carrier 6
- MSI MSU 420/302 Mobile Unit 6
- MSI Raise Robot 6

PORTABLE SHOTCRETE SOLUTIONS

- MSI Portable Mix Station 7
- MSI Underground Storage & Mixing Station 7
- MSI Portable Load-out Station 7
- MSI Bulk Shotcrete Transport 7

SHOTCRETE MATERIAL & ACCESSORIES

- Shotcrete Nozzles & Parts 8
- Shotcrete Material & Additives 8

SOLUTION FLOWCHARTS 10, 11, 12, 13

SHOTCRETE EQUIPMENT



ALIVA AL-237 COMPACT SHOTCRETE UNIT



The AL-237 is a compact concrete spraying machine for dry shotcrete as well as for small wet shotcrete application of mortar. The low filling height of the hopper allows easy handling of pre-bagged materials with little effort. The integrated FU (frequency changer) enables an infinitely variable speed of the rotor, and with it, the conveying capacity for each specific job. With a range of conveying capacity from 0.4 to 4.0 m³/h, the AL-237 is suitable especially (but not only) for:

- Concrete renovation
- Ponds & swimming pools
- Mining
- Joint fillings
- Slope protection & stabilization
- Canal renovation (sewage)

ALIVA-257 WET/DRY SHOTCRETE UNIT



The AL-257 is the universal machine for the application of dry and wet shotcrete in the thin-stream method. Weighing in at 750 kg and as small as a small dry shotcrete machine, the AL-257 fits on every job site and is easy to install and operate.

With its unbelievable output capacity range from 0.7-9.6 m³/hr, the machine works on small concrete renovation work as efficient as on big slope protection or in mines. Less maintenance and wear cost make it the ideal shotcrete machine for all applications.

- Concrete renovation
- Joint fillings
- Concrete restoration
- Ponds & swimming pools
- Slope protection & rock consolidation
- Mining & tunnel applications
- Canal renovation (sewage)

SHOTCRETE EQUIPMENT



ALIVA AL-267 WET/DRY SHOTCRETE UNIT



The AL-267 is a multi-functional machine for wet and dry application of sprayed concrete in the thin stream method. With an output capacity of 4-21 m³/hr and a modular design, the 267 fits a wide range of applications.

- Concrete renovation
- Ponds & swimming pools
- Mining & tunnel applications
- Joint fillings
- Slope protection & stabilization
- Canal renovation (sewage)

ALIVA 302.1 ROBOTIC TELESCOPING SPRAY ARM



The telescope spraying arm Aliva 302 is used for the application of sprayed concrete in mines, small galleries and excavations. This quality Aliva product can assist the shotcrete team in safely applying high quality targeted shotcrete with minimum rebound and waste

With its simple and rigid construction, the Aliva 302 is very suitable for mounting onto different types of carriers. The telescope spraying arm is available in two different types:

Type - PROP: Electric remote control (wireless remote control optional) hydraulic aggregate with motor.

Type - AIR: Hydraulic remote control, hydraulic aggregate with air motor.

Concrete renovation with sprayed concrete in the dry shotcrete method guarantees good bond strength and impeccable compaction. No matter the project, Aliva shotcrete machines are the right choice.

SHOTCRETE EQUIPMENT

MULTICRETE INTEGRAL SHOTCRETE UNIT



This easily transported machine consists of an Aliva dry mix shotcrete machine and a Multicrete Predampener, mounted together on a common frame. The hopper on the Predampener allows for a continuous feed of pre-blended dry mix shotcrete, even during bulk bag changes. The feed auger located under the hopper then feeds a mix auger where water is added to suppress dust and to allow the nozzleman to easily regulate the water at the nozzle.

This unit has both electric and pneumatic power options.



HYBRID-WET® SHOTCRETE CARRIER

The shotcrete carrier includes a dry mix hopper, a wet/dry mix shotcrete spraying machine, and a mixing auger. This mixing auger wets the dry mix as it is conveyed from the dry mix hopper to the shotcrete spraying machine on a common mobile frame.

The shotcrete spraying machine comprises an inlet hopper receiving the wet mix shotcrete from the mixing auger, a rotor with chambers rotatable from a loading position in communication with inlet hopper, and a discharging position in communication with a pneumatic conveying line. The pneumatic conveying line conveys the wet mix shotcrete to a nozzle commonly supported on the mobile frame.

SHOTCRETE EQUIPMENT

MULTICRETE HURON 4 MOBILE CARRIER



The Multicrete Huron 4 shotcrete carrier includes a state-of-the-art Aliva 257 wet/dry shotcrete machine on the rear and an Aliva 302 wet mix shotcrete spraying arm on the front. Additionally, it features enhanced hydraulics, self-contained liquid accelerator storage, and pumping system - all on a Huron 4 transmixer chassis. This compact, maneuverable, tough unit gets the job done!



MULTICRETE MSU 420/302

Multicrete's MSU 420/302 is a complete mobile shotcrete unit with front forks and a shotcrete boom with a reach of over 18 feet!



MULTICRETE RAISE ROBOT

The RAISE ROBOT® is a remotely controlled robotic assembly for the spraying of shotcrete used in shafts and raises of subterranean excavations. Together with the RAISE RANGER®, these robotic units are designed for use in mines and on large civil construction projects. Standard RAISE ROBOTS® are designed for use in raises a minimum of 1.5 metres diameter up to a maximum of 5.5 metres diameter. Spring-loaded retractable arms stabilize the RAISE ROBOT® and allow for undulations along the interior surface of the raise.

In 2008 Multicrete completed a 3.5 metre diameter x 300 metre raise. A second raise, over 400 metres in depth, was completed in 2009.

SHOTCRETE EQUIPMENT



MULTICRETE PORTABLE MIX STATION

The ideal shotcrete mixing solution for underground applications. This unit will accept dry, pre-mixed shotcrete, mix it to exact water/cement ratio and load it into an awaiting Transmixer for transport to application site.

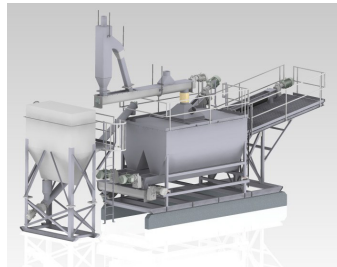

MULTICRETE UNDERGROUND STORAGE & MIXING STATION

Multicrete specializes in designing and manufacturing underground shotcrete storage and mixing stations which can provide solutions to your underground shotcrete needs. Whether it is a wet or Hybrid-Wet® end product, Multicrete can get you up and producing.



MULTICRETE PORTABLE LOAD-OUT STATION

A totally portable load-out station capable of receiving bulk shotcrete bags or cassettes. Infeed hopper & auger move material to the feed auger for carrier loading. This unit can be set up in several locations.



MULTICRETE BULK SHOTCRETE TRANSPORT

The perfect bulk dry premixed shotcrete solution - transportation and delivery systems for bulk shotcrete product right to your door! The augering system will deliver product to your storage station.

MATERIAL & ACCESSORIES

SHOTCRETE NOZZLES AND PARTS



We stock a complete line of nozzles, bodies, hose, clamps, and additional parts to fill your shotcreting needs.

We also stock a complete lineup of wear plates, rotors, and other parts for most Aliva equipment.

SHOTCRETE MATERIAL



We stock and carry a variety of shotcrete materials, including:

MEGASTICK® DRY & WET
Shotcrete mixtures

XPR SHOTCRETE
For cold temperature application.

FLASH-SET SHOTCRETE
For applications requiring rapid set times.

Additionally, Multicrete has the ability to add any number of shotcrete additives to the mix design:

DRAMIX® STEEL FIBER
A steel fiber to enhance durability and strength

MULTICRETE SHOTCRETE SET ACCELERATOR
Chloride-free designed for use with shotcrete

Multicrete manufactures shotcrete in a variety of packaging options: bulk, bulk bags, or bulk cassettes - tailored for you.

EQUIPMENT SOLUTIONS



The Hybrid-Wet® Shotcrete Carrier is the ultimate in shotcrete technology. Blending the best of both worlds, Hybrid-Wet® technology utilizes dry premixed shotcrete, and turns the product into a Hybrid-Wet® state for application.

The Hybrid Wet® Shotcrete Application Carrier is based on simplicity. Load and haul dry, pre-mixed material to the shooting site. Water is added to the Mixing Auger just before the Aliva 257 Shotcrete Pump and it is sprayed “wet” at a low slump for reduced accelerator needs and high strength and adhesion.

This unit can also spray “predampened” dry shotcrete!



HYBRID-WET® SHOTCRETE

- Mitigates the dust associated with dry process shotcrete application methods
- Reduces the amount of overspray and waste associated with wet process shotcrete application methods
- Reduces the amount of expensive admixtures needed to delay set times, increase slump flowability, or accelerator typically used in the wet process shotcrete application methods
- Is a stronger, quicker setting product that allows productivity to continue without delays



A single Hybrid-Wet® Shotcrete Application Carrier reduces the number of pieces of equipment associated with dry or wet processes. Start and stop as you need production. Clean-up takes about 10 minutes.

SOLUTION FLOWCHART

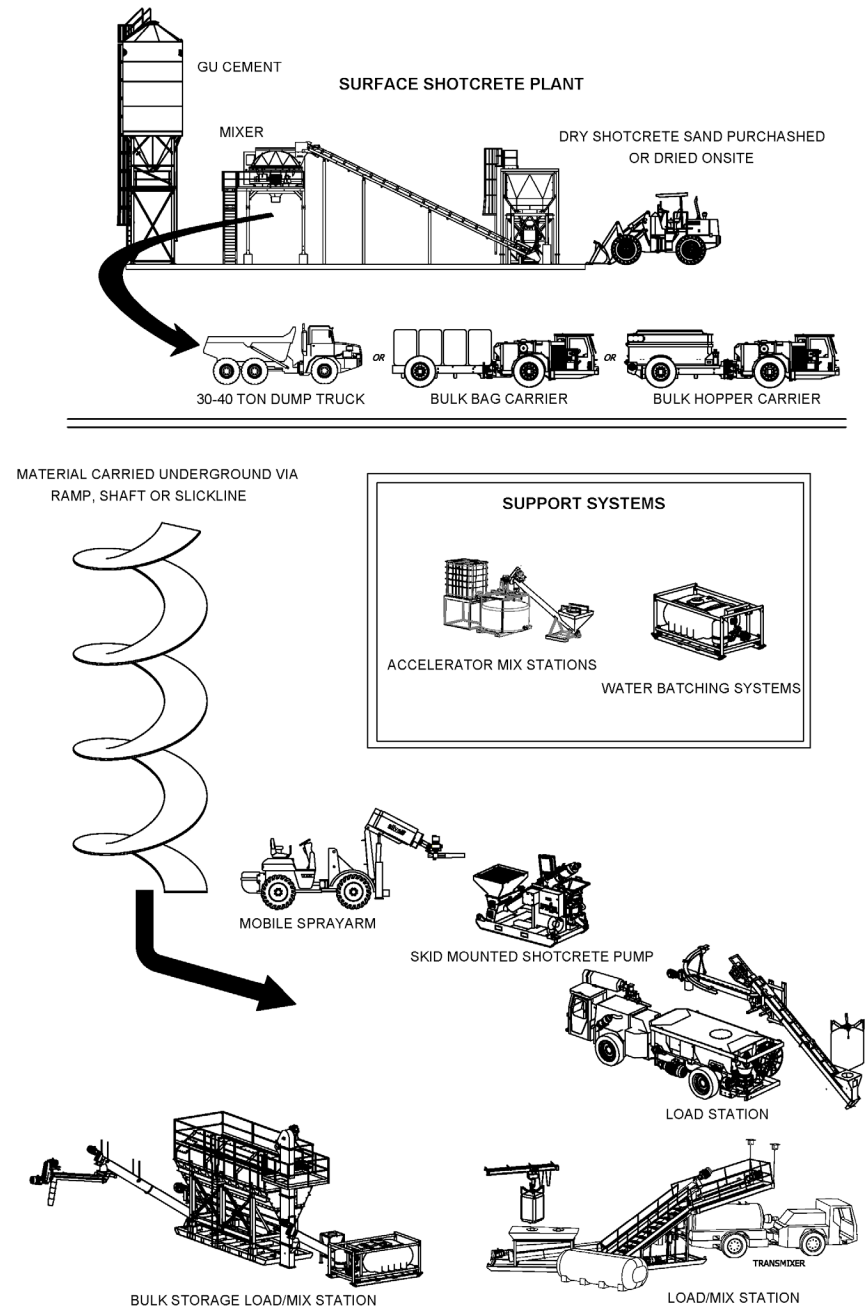

SOLUTION FLOWCHART

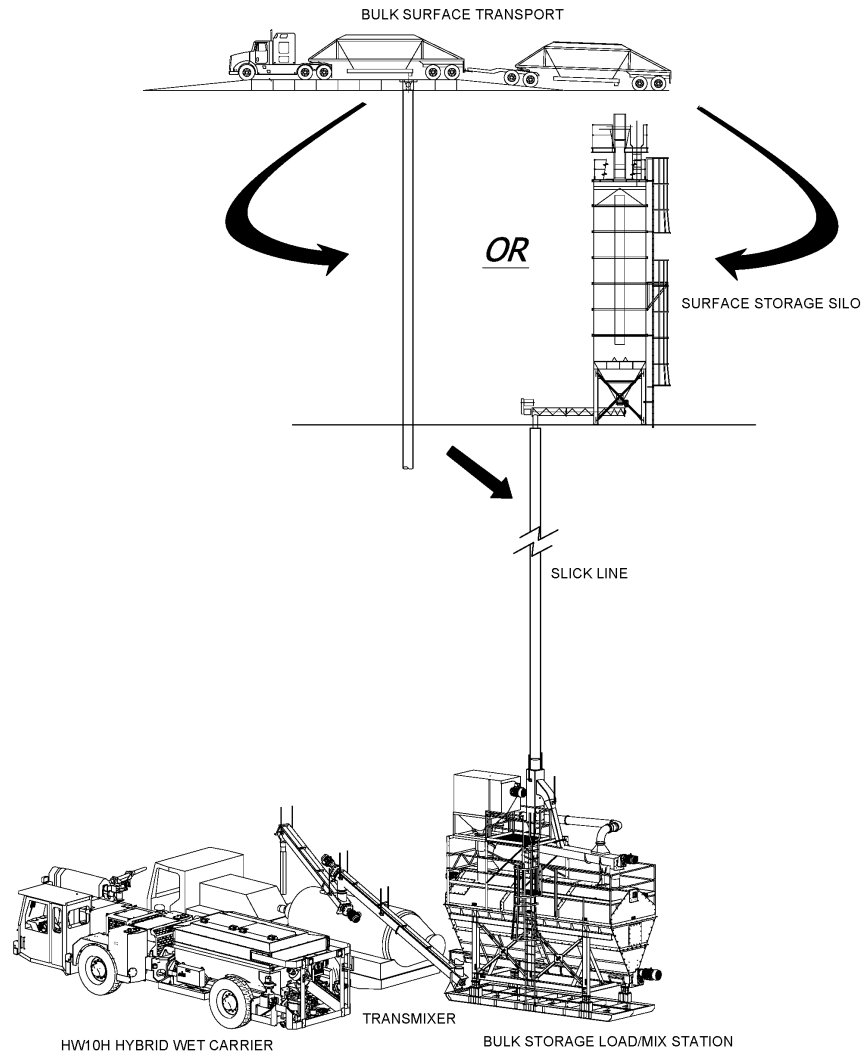

SOLUTION FLOWCHART

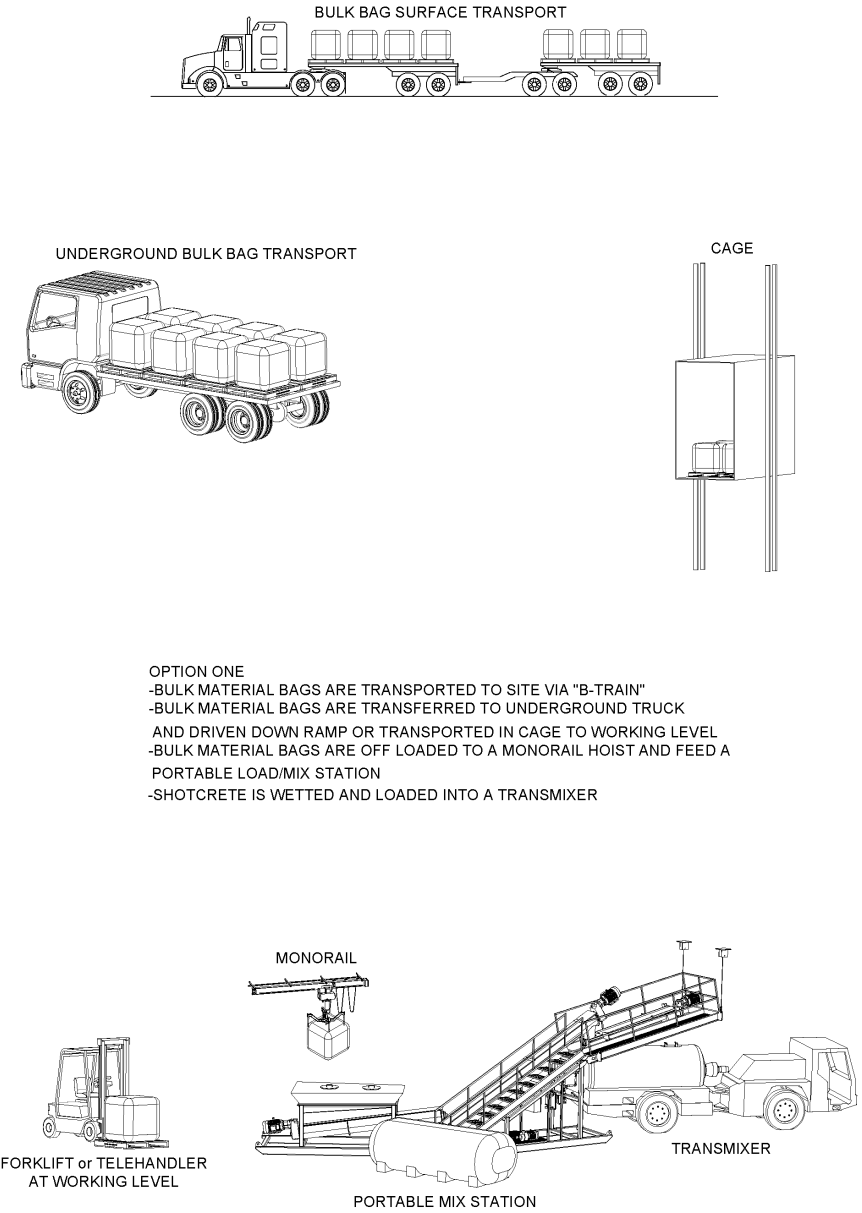

SOLUTION FLOWCHART

BULK SURFACE CASSETTE TRANSPORT

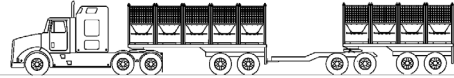

RAMP

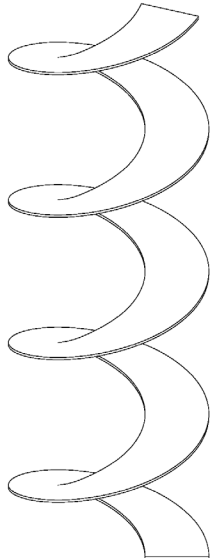

UNDERGROUND CASSETTE TRANSPORT

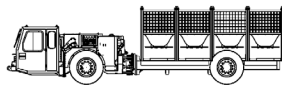

OPTION ONE

- BULK MATERIAL CASSETTES ARE TRANSPORTED TO SITE VIA "B-TRAIN"
- BULK MATERIAL CASSETTES ARE TRANSFERRED TO UNDERGROUND CARRIER AND DRIVEN DOWN RAMP TO WORKING LEVEL
- BULK MATERIAL CASSETTES ARE OFF LOADED WITH A MONORAIL HOIST AND FEED EITHER 1) PORTABLE LOAD/MIX STATION OR 2)A BULK STORAGE LOAD MIX STATION
- SHOTCRETE IS WETTED AND LOADED INTO A TRANSMIXER

MONORAIL

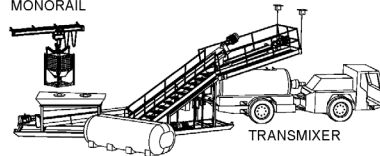

PORTABLE MIX STATION

TRANSMIXER

OR

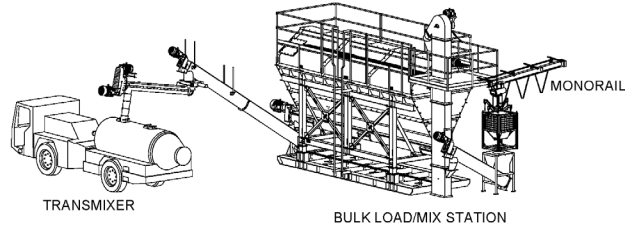

TRANSMIXER

BULK LOAD/MIX STATION



WE ALSO PROVIDE SOLUTIONS FOR...

CONCRETE



Multicrete has several branches that have Redi-Mix batching, delivery and pumping capabilities. Our plants can also produce dry pre-mixed concrete, wet aggregate and bulk cement bagging. We have portable batching plants and also build batch plants.

GROUT



Multicrete can produce a variety of grouting materials from non-shrink to water cut-off grout mixes. We can produce grout in 25 kg bags to bulk bags. We are distributors of CHEMGROUT, MINEPRO, ICTUS, and MSI grout equipment and accessories.

SPECIALTY EQUIPMENT



Multicrete manufactures batch plants, underground loading stations, mixing plants, shotcrete carrier & application units, bulk delivery systems, transport systems and more. Working with your existing infrastructure and equipment, we can provide solutions for your unique problems.



FIND US ONLINE



LIKE US
[FACEBOOK.COM/MULTICRETESYSTEMS](https://www.facebook.com/multicretesystems)



FOLLOW & RETWEET US
[@MULTICRETE](https://twitter.com/multicrete)



ADD US TO YOUR CIRCLES
SEARCH "MULTICRETE" ON GOOGLE+



CHECK OUT OUR VIDEOS
[YOUTUBE.COM/MULTICRETESYSTEMS](https://www.youtube.com/multicretesystems)



CONNECT WITH US
SEARCH "MULTICRETE SYSTEMS" ON LINKEDIN



SCAN THE CODE TO VISIT OUR WEBSITE AT
WWW.MULTICRETESYSTEMS.COM